



US 20110127498A1

(19) **United States**

(12) **Patent Application Publication**  
**Jung et al.**

(10) **Pub. No.: US 2011/0127498 A1**

(43) **Pub. Date: Jun. 2, 2011**

(54) **ORGANIC LIGHT EMITTING DIODE  
DISPLAY DEVICE**

**Publication Classification**

(75) Inventors: **Woo-Suk Jung**, Yongin-City (KR);  
**Soon-Ryong Park**, Yongin-City  
(KR); **Duk-Jin Lee**, Yongin-City  
(KR); **Sa-Bang Um**, Yongin-City  
(KR); **Jae-Yong Kim**, Yongin-City  
(KR)

(51) **Int. Cl.**  
**H01L 51/50** (2006.01)

(52) **U.S. Cl.** ..... **257/40; 257/E51.018**

(73) Assignee: **SAMSUNG MOBILE DISPLAY  
CO., LTD.**, Yongin-City (KR)

(57) **ABSTRACT**

An organic light emitting diode (OLED) display device includes a first substrate; a first electrode positioned on the first substrate; an organic light emission layer positioned on the first electrode; a second electrode positioned on the organic light emission layer; and a capping layer positioned on the second electrode to cover the organic light emission layer and including an ultraviolet (UV) interception material intercepting UV rays irradiated to the organic light emission layer from the exterior.

(21) Appl. No.: **12/873,003**

(22) Filed: **Aug. 31, 2010**

(30) **Foreign Application Priority Data**

Dec. 1, 2009 (KR) ..... 10-2009-0117927

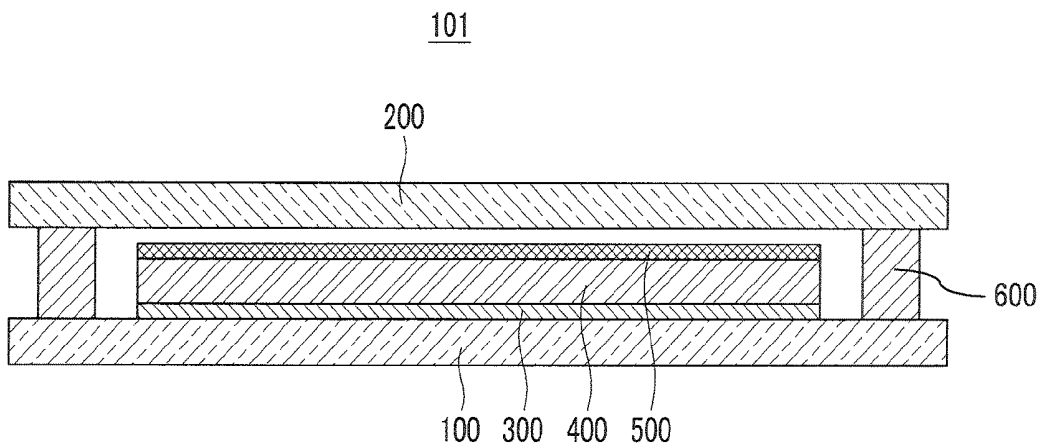

FIG. 1

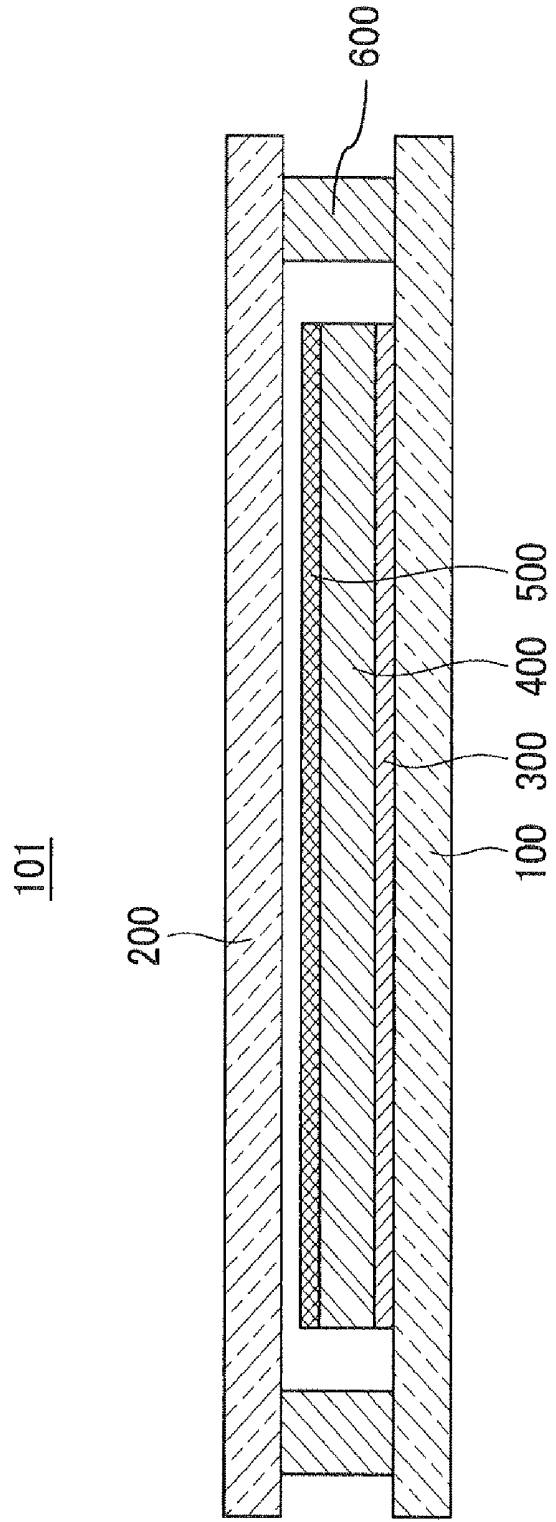

FIG. 2

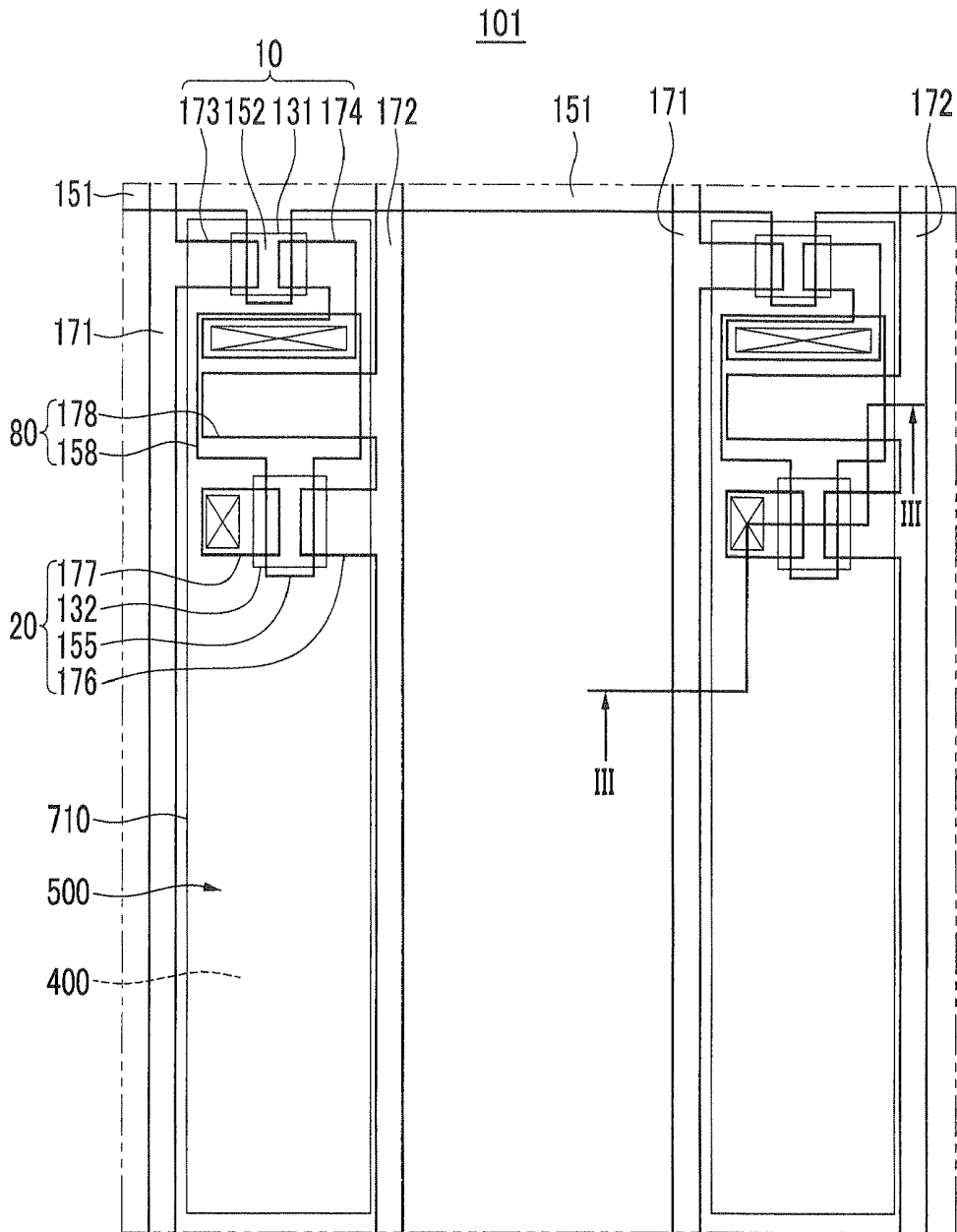

FIG. 3

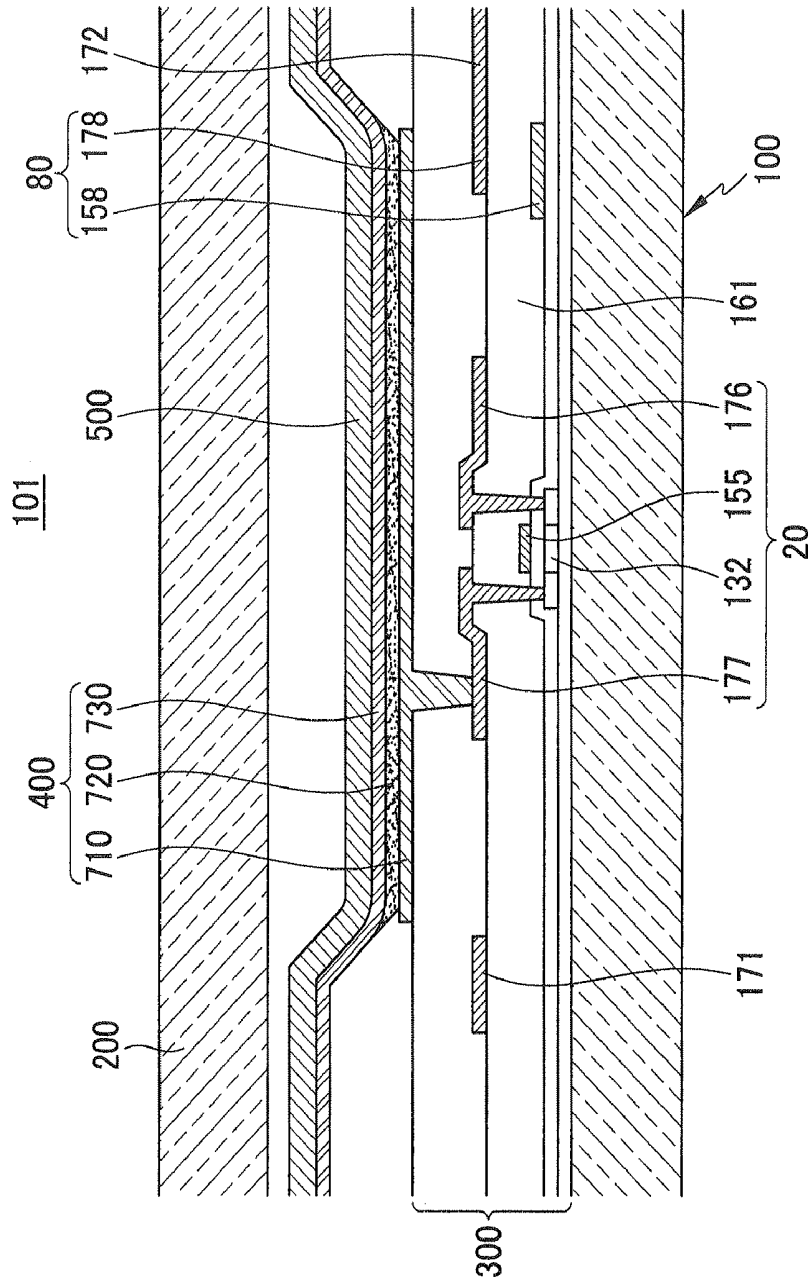
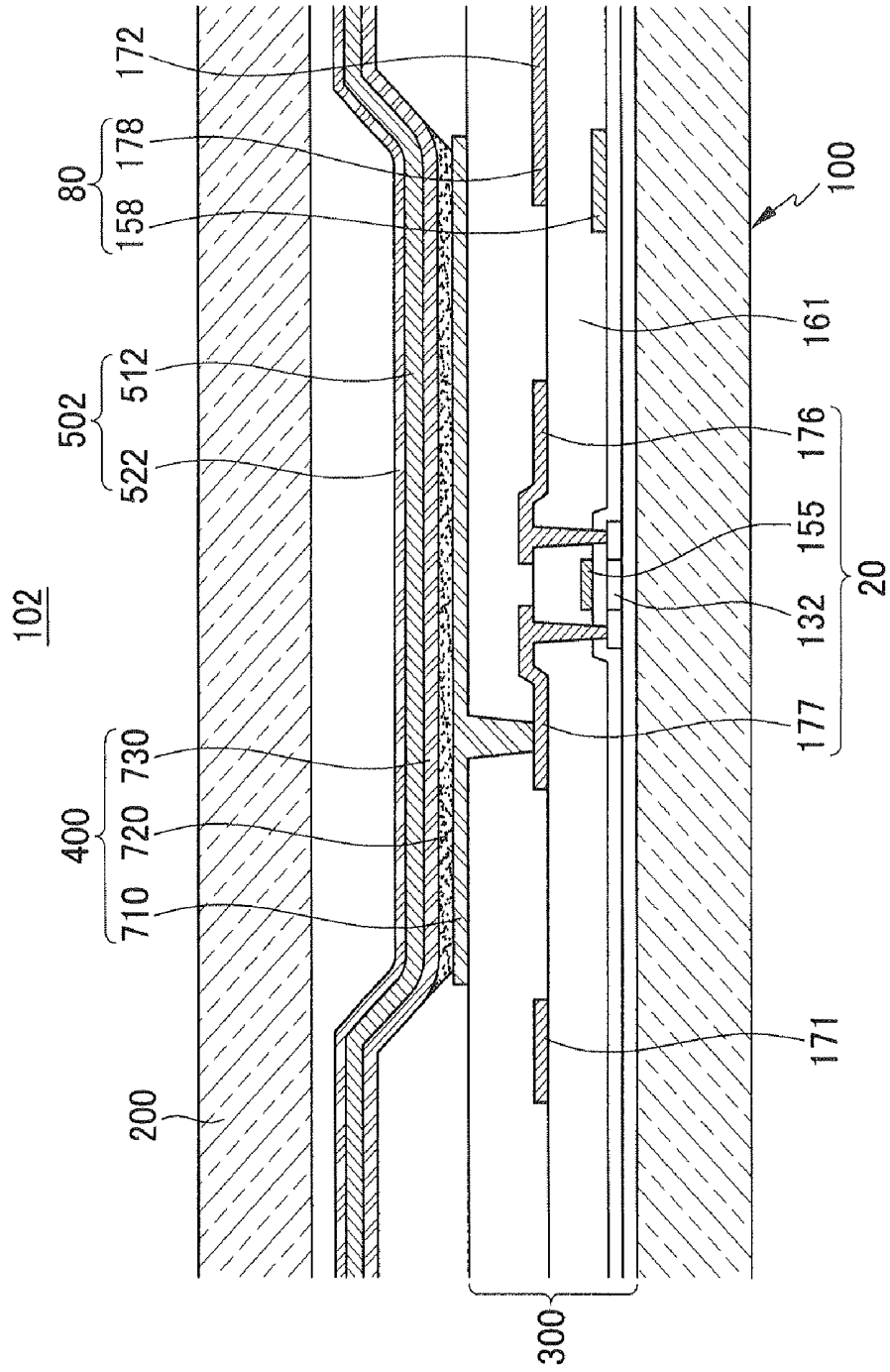

FIG. 4



## ORGANIC LIGHT EMITTING DIODE DISPLAY DEVICE

### CLAIM OF PRIORITY

**[0001]** This application makes reference to, incorporates the same herein, and claims all benefits accruing under 35 U.S.C. §119 from an application earlier filed in the Korean intellectual property Office on 1 Dec. 2009 and there duly assigned Serial No. 10-2009-0117927.

### BACKGROUND OF THE INVENTION

**[0002]** 1. Field of the Invention

**[0003]** The described technology relates generally to an organic light emitting diode (OLED) display device and, more particularly, to an OLED display device having a capping layer.

**[0004]** 2. Description of the Related Art

**[0005]** Recently, organic light emitting diode (OLED) display devices have received much attention as display devices for displaying images.

**[0006]** An OLED display device has self-emission characteristics, eliminating the necessity of a separate light source, unlike a liquid crystal display (LCD) device, such that the OLED display device may be fabricated to be thinner and lighter. Also, the OLED display device has high quality characteristics such as low power consumption, high luminance, a high response speed, and the like. The material constituting an organic light emission layer of the OLED display device is however vulnerable to ultraviolet (UV) rays and moisture.

**[0007]** The above information disclosed in this Background section is only for enhancement of understanding of the background of the described technology and therefore it may contain information that does not form the prior art that is already known in this country to a person of ordinary skill in the art.

### SUMMARY OF THE INVENTION

**[0008]** It is therefore an object for the present invention to provide an improved organic light emitting diode (OLED) display device protecting an organic light emission layer against ultraviolet (UV) rays and moisture.

**[0009]** An exemplary embodiment of the present invention provides an OLED display device including a first substrate; a first electrode positioned on the first substrate; an organic light emission layer positioned on the first electrode; a second electrode positioned on the organic light emission layer; and a capping layer positioned on the second electrode to cover the organic light emission layer and including an ultraviolet (UV) interception material intercepting UV rays irradiated to the organic light emission layer from the exterior of the OLED display device.

**[0010]** The UV interception material may include one or more of zinc oxide, titanium oxide, iron oxide, and magnesium oxide.

**[0011]** The capping layer may be an amorphous organic film or an amorphous inorganic film.

**[0012]** The capping layer may include one or more of a-NPD, NPB, TPD, m-MTDATA, Alq3, LiF, and CuPc.

**[0013]** The capping layer may be an inorganic film including silicon (Si).

**[0014]** The capping layer may be deposited by the atom or by the molecule.

**[0015]** The capping layer may further include a UV interception layer including a UV interception material.

**[0016]** The UV interception layer may be separated from the second electrode.

**[0017]** In accordance with an exemplary embodiment of the present invention, because the organic light emission layer of the OLED display device is protected against UV and moisture, the life span of the OLED display device may be lengthened.

### BRIEF DESCRIPTION OF THE DRAWINGS

**[0018]** A more complete appreciation of the invention, and many of the attendant advantages thereof, will be readily apparent as the same becomes better understood by reference to the following detailed description when considered in conjunction with the accompanying drawings in which like reference symbols indicate the same or similar components, wherein:

**[0019]** FIG. 1 is a cross-sectional view of an organic light emitting diode (OLED) display device constructed as a first exemplary embodiment of the present invention;

**[0020]** FIG. 2 is a layout view showing the structure of pixels of the OLED display device constructed as the first exemplary embodiment of the present invention;

**[0021]** FIG. 3 is a cross-sectional view taken along line III-III in FIG. 2; and

**[0022]** FIG. 4 is a cross-sectional view showing a major part of the OLED display device constructed as a second exemplary embodiment of the present invention.

### DETAILED DESCRIPTION OF THE INVENTION

**[0023]** The exemplary embodiments will be described more fully hereinafter with reference to the accompanying drawings, in which exemplary embodiments are shown. As those skilled in the art would realize, the described embodiments may be modified in various different ways, all without departing from the spirit or scope of the present invention.

**[0024]** In describing the exemplary embodiments, the same reference numerals are used for elements having the same constructions and that are representatively described in a first exemplary embodiment, and in remaining exemplary embodiments, different configurations from those of the first exemplary embodiment will be described.

**[0025]** In order to clarify the exemplary embodiments, parts that are not connected with the description will be omitted, and the same elements or equivalents are referred to by the same reference numerals throughout the specification.

**[0026]** The size and thickness of each element are arbitrarily shown in the drawings, and the exemplary embodiment is not limited thereto.

**[0027]** In the drawings, the thickness of layers, films, panels, regions, etc., are exaggerated for clarity. Also, in the drawings, the thickness of some layers and regions are exaggerated for the sake of brevity. It will be understood that when an element such as a layer, film, region, or substrate is referred to as being "on" another element, it can be directly on the other element or intervening elements may also be present. In contrast, when an element is referred to as being "directly on" another element, there are no intervening elements present.

**[0028]** In general, the OLED display device includes an organic light emitting element that emits light. The organic light emitting element includes an organic light emission layer, and first and second electrodes with the organic light

emission layer interposed therebetween. The organic light emission layer of the organic light emitting element may be formed of low molecular organic materials.

[0029] The material constituting the organic light emission layer is however physically vulnerable to ultraviolet (UV) rays and moisture.

[0030] The above information disclosed is only for enhancement of understanding of the background of the described technology and therefore it may contain information that does not form the prior art that is already known in this country to a person of ordinary skill in the art.

[0031] In the accompanying drawings, an active matrix (AM) type of OLED display device with a 2Tr-1Cap structure in which a single pixel has two thin film transistors (TFTs) and one storage capacitor is illustrated, but the exemplary embodiment is not meant to be limited thereto. That is, in the OLED display device, a single pixel may have three or more TFTs and two or more storage capacitors, and the OLED display device may have various other structures with more wiring. Here, a pixel refers to a minimum unit for displaying an image, and the OLED display device displays an image through a plurality of pixels.

[0032] An OLED display device **101** constructed as a first exemplary embodiment will now be described with reference to FIGS. **1** through **4**.

[0033] FIG. **1** is a cross-sectional view of the OLED display device constructed as a first exemplary embodiment.

[0034] As shown in FIG. **1**, the OLED display device **101** constructed as the first exemplary embodiment includes a first substrate **100**, a second substrate **200**, a wiring unit **300**, an organic light emitting element **400**, and a capping layer **500**.

[0035] The first and second substrates **100** and **200** are insulating substrates which may be formed of glass, polymer, stainless steel, or the like, and at least one of the first and second substrates **100** and **200** is made of a light-transmissive material. The wiring unit **300** and the organic light emitting element **400** are positioned on the first substrate **100**, and the second substrate **200** faces toward the first substrate **100** with the wiring unit **300** and the organic light emitting element **400** interposed therebetween. The first and second substrates **100** and **200** are attached and hermetically sealed by a sealant **600** with the organic light emitting element **400** interposed therebetween, and protect the wiring unit **300** and the organic light emitting element **400** against external interference.

[0036] The wiring unit **300** includes switching and driving thin film transistors (TFTs) **10** and **20** (See FIG. **2**), and transfers a signal to the organic light emitting element **400** in order to drive the organic light emitting element **400**. The organic light emitting element **400** emits light in accordance with the signal received from the wiring unit **300**.

[0037] The organic light emitting element **400** is positioned on the wiring unit **300**. The organic light emitting element **400** may be in direct contact with the wiring unit **300**.

[0038] The organic light emitting element **400** is positioned on a display area of the first substrate **100**, and is formed by using microelectromechanical systems (MEMS) such as photolithography. The organic light emitting element **400** receives a signal from the wiring unit **300** and displays an image in accordance with the received signal. The capping layer **500** is positioned on the organic light emitting element **400**. The capping layer **500** may be in direct contact with the organic light emitting element **400**.

[0039] The capping layer **500**, covering the organic light emitting element **400**, restrains (or suppresses) moisture from

being introduced into an organic light emission layer **720** (shown in FIG. **3**) included in the organic light emitting element **400** (to be described), and intercepts UV rays irradiated to the capping layer **500** to restrain UV rays from being irradiated to the organic light emission layer **720** via the capping layer **500**. The capping layer **500** may cover the entirety of the organic light emitting element **400**.

[0040] An internal structure of the OLED display device **101** constructed as the first exemplary embodiment will now be described with reference to FIGS. **2** and **3**.

[0041] FIG. **2** is a layout view showing the structure of pixels of the OLED display device as the first exemplary embodiment. FIG. **3** is a cross-sectional view taken along line in FIG. **2**.

[0042] The structure of the wiring unit **300** and the organic light emitting element **400** are illustrated in FIGS. **2** and **3**, but the exemplary embodiment is not limited thereto. The wiring unit **300** and the organic light emitting element **400** may be formed to have various structures within the scope in which the skilled person in the art can easily modify and implement them. For example, in the accompanying drawings, an active matrix (AM) type of OLED display device with a 2Tr-1Cap structure in which a single pixel has two TFTs and one storage capacitor is illustrated, but the exemplary embodiment is not meant to be limited thereto. That is, the number of TFTs, the number of storage capacitors, and the number of wires of the display device are not limited. A pixel is a minimum unit for displaying an image, and the OLED display device displays an image through a plurality of pixels.

[0043] As shown in FIGS. **2** and **3**, the OLED display device **101** includes a switching TFT **10**, a driving TFT **20**, a storage capacitor **80**, and the organic light emitting element **400** formed at each pixel. Here, the configuration including the switching TFT **10**, the driving TFT **20**, and the storage capacitor **80** is called the wiring unit **300**. The wiring unit **300** further includes a gate line **151** disposed along one direction of the first substrate **100**, a data line **171** electrically insulated from the gate line **151** and crossing the gate line **151**, and a common power line **172**. Here, one pixel may be defined by the gate line **151**, the data line **171**, and the common power line **172** as boundaries, but is not limited thereto.

[0044] The organic light emitting element **400** includes a first electrode **710**, the organic light emission layer **720** formed on the first electrode, and a second electrode **730** formed on the organic light emission layer **720**. The first electrode **710**, the organic light emission layer **720**, and the second electrode **730** constitute the organic light emitting element **400**. Here, the first electrode **710** is an anode, which is a hole injection electrode, and the second electrode **730** is a cathode, which is an electron injection electrode. The first exemplary embodiment is however not limited thereto, and the first electrode **710** may be a cathode and the second electrode **730** may be an anode depending on a driving method of the OLED display device.

[0045] Holes and electrons from the first and second electrodes **710** and **730** are injected into the organic light emission layer **720**, and when excitons formed as the holes and electrodes injected into the organic light emission layer **720** are combined change from an excited state to a base state, the organic light emission layer **720** emits light.

[0046] Also, in the OLED display device **101** constructed as the first exemplary embodiment, the first electrode **710** may be made of a light reflective material such as aluminum (Al), and the second electrode **730** may be made of a light

transmissive material including indium tin oxide (ITO), indium zinc oxide (IZO), or the like, which is transparent or translucent. The exemplary embodiment is however not limited thereto, and one or more of the first and second electrodes **710** and **730** may be made of a transparent or translucent conductive material.

[0047] Also, in the OLED display device **101** constructed as the first exemplary embodiment, the organic light emitting element **400** emits light toward the second substrate **200**. The exemplary embodiment is however not limited thereto, and light emitted from the organic light emitting element **400** may proceed toward one or more of the first and second substrates **100** and **200**. That is, the OLED display device **101** constructed as the first exemplary embodiment is a top emission type of OLED display device, but an OLED display device constructed as a different exemplary embodiment may be a bottom emission type of OLED display device or a dual-emission type of OLED display device.

[0048] The storage capacitor **80** includes a pair of capacitor plates **158** and **178** disposed with an interlayer insulating layer **161** interposed therebetween. Here, the interlayer insulating layer **161** serves as a dielectric material, and capacitance of the storage capacitor **80** is determined by electric charges charged in the storage capacitor **80** and the voltage between the two capacitor plates **158** and **178**.

[0049] The switching TFT **10** includes a switching semiconductor layer **131**, a switching gate electrode **152**, a switching source electrode **173**, and a switching drain electrode **174**. The driving TFT **20** includes a driving semiconductor layer **132**, a driving gate electrode **155**, a driving source electrode **176**, and a driving drain electrode **177**.

[0050] The switching TFT **10** is used as a switching element for selecting pixels to be illuminated. The switching gate electrode **152** is connected with the gate line **151**. The switching source electrode **173** is connected with the data line **171**. The switching drain electrode **174** is disposed to be separated from the switching source electrode **173**, and is connected with one capacitor plate **158**.

[0051] The driving TFT **20** applies driving power for making the organic light emission layer **720** of the organic light emitting element **400** within a selected pixel emit light to the first electrode **710**. The driving gate electrode **155** is connected with the capacitor plate **158** connected with the switching drain electrode **174**. The driving source electrode **176** and another capacitor plate **178** are connected with the common power line **172**, respectively. The driving drain electrode **177** is connected with the first electrode **710** of the organic light emitting element **400** via a contact hole.

[0052] With such a structure, the switching TFT **10** operates by a gate voltage applied to the gate line **151** to transfer a data voltage applied to the data line **171** to the driving TFT **20**. The voltage difference between a common voltage applied from the common power line **172** to the driving TFT **20** and the data voltage transferred from the switching TFT **10** is stored in the storage capacitor **80**, and the current corresponding to the voltage stored in the storage capacitor **80** flows to the organic light emitting element **400** via the driving TFT **20**, making the organic light emitting element **400** emit light.

[0053] The capping layer **500** formed on the second electrode **730** covers the organic light emitting element **400** including the organic light emission layer **720**. The capping layer **500** may cover the entirety of the organic light emitting

element **400** including the organic light emission layer **720**, the second electrode **730** and the first electrode **710**.

[0054] The capping layer **500** includes a UV interception material. The UV interception material includes one or more of zinc oxide (ZnO), titanium oxide (TiO<sub>2</sub>), iron oxide (Fe<sub>2</sub>O<sub>3</sub>), and magnesium oxide (MgO). The capping layer **500** including the UV interception material intercepts UV rays irradiated to the capping layer **500** from the exterior via the second substrate **200**. Because UV rays irradiated toward the capping layer **500** via the second substrate **200** from the exterior are intercepted, UV irradiation from the exterior to the organic light emission layer **720** covered by the capping layer **500** can be restrained. Namely, the life span of the organic light emission layer **720** covered by the capping layer **500** may be increased because of the UV interception function of the capping layer **500**.

[0055] The capping layer **500** may be formed as an amorphous organic film or an amorphous inorganic film.

[0056] In detail, the capping layer **500** may be formed as an amorphous organic film by depositing one or more of a-NPD, NPB, TPD, m-MTDATA, Alq<sub>3</sub>, LiF, and CuPc and the above-mentioned UV interception material by the atom or by the molecule.

[0057] The capping layer **500** may be formed as an amorphous inorganic film by depositing a compound containing silicon (Si) such as silicon nitride (SiN<sub>x</sub>), silicon oxide (SiO<sub>x</sub>), silicon oxide/nitride (SiO<sub>x</sub>N<sub>y</sub>), and the like, and the above-mentioned UV interception material by the atom or by the molecule.

[0058] Because the capping layer **500** is formed to be amorphous, the capping layer **500** may be maintained to be transparent. That is, because the capping layer **500** is formed in the amorphous state, light emitted from the organic light emission layer **720** may be irradiated to the exterior via the capping layer **500** and the second substrate **200** without a large loss of light emitted, so as to be implemented as an image.

[0059] Also, the capping layer **500** may be formed as the amorphous organic film or the amorphous inorganic film, and the molecules or atoms included in the capping layer **500** form a dense structure. Because the capping layer **500** itself has a dense structure, moisture that can be introduced from the external environment into the organic light emission layer **720** of the organic light emitting element **400** from the exterior may be fundamentally intercepted.

[0060] In addition, because the capping layer **500** is positioned on the organic light emitting element **400** and covers the organic light emitting element **400**, the capping layer **500** may protect the organic light emitting element **400** against external interference. In this manner, because the capping layer **500** protects the organic light emitting element **400**, the space between the first and second substrates **100** and **200** may be minimized, and accordingly, the overall thickness of the OLED display device **101** may become thinner.

[0061] Also, because the capping layer **500** may be positioned on the second electrode **730** of the organic light emitting element **400**, reflection of external light by the second electrode **730** may be restrained. Thus, because reflection of external light by the organic light emitting element **400** is restrained because of the capping layer **500**, an element such as an optical film generally formed on the second substrate **200** to restrain reflection of external light may be omitted. Thus, because such an element as the optical film generally positioned on the second substrate **200** may be omitted by virtue of the capping layer **500**, luminous efficiency of the

OLED display device **101** can be improved. Here, the capping layer **500** may be in direct contact with the second electrode **730** of the organic light emitting element **400**.

[0062] As described above, because the OLED display device **101** constructed as the first exemplary embodiment includes the capping layer **500** including the UV interception material, damage to the organic light emission layer **720** due to UV rays and moisture may be restrained, resulting in the lengthened lifespan of the OLED display device **101**.

[0063] Meanwhile, in a case where a window-integrated OLED display device is manufactured by attaching a window protecting the OLED display device **101** on the second substrate **200**, a UV thermosetting adhesive resin (not shown) is formed between the window and the second substrate **200**, the window is bonded to the second substrate **200** by using the UV thermosetting adhesive resin, and the UV thermosetting adhesive resin is then hardened by using UV rays. During the manufacture of the window-integrated OLED display device, the UV interception material included in the capping layer **500** of the OLED display device constructed as the first exemplary embodiment intercepts UV rays, which are the means for hardening the UV thermosetting adhesive resin, so damage to the organic light emission layer **720** by UV rays may be restrained.

[0064] An OLED display device **102** constructed as a second exemplary embodiment will now be described with reference to FIG. 4.

[0065] FIG. 4 is a cross-sectional view showing a major part of the OLED display device constructed as a second exemplary embodiment.

[0066] As shown in FIG. 4, a capping layer **502** of the OLED display device **102** constructed as the second exemplary embodiment is a multiple layer and includes a base layer **512** and a UV interception layer **522**. The base layer **512** and the UV interception layer **522** are different from each other and are separately disposed from each other.

[0067] The base layer **512** is formed on the second electrode **730** to cover the organic light emitting element **400** including the organic light emission layer **720**. The base layer **512** is formed as an amorphous organic film or as an amorphous inorganic film. In detail, the base layer **512** is formed as an amorphous organic film by depositing one or more of a-NPD, NPB, TPD, m-MTDATA, Alq<sub>3</sub>, LiF, and CuPc by the atom or by the molecule, or is formed as an amorphous inorganic film by depositing a compound containing silicon (Si) such as silicon nitride (SiN<sub>x</sub>), silicon oxide (SiO<sub>x</sub>), silicon oxide/nitride (SiO<sub>x</sub>N<sub>y</sub>), and the like, by the atom or by the molecule. Because the base layer **512** is formed to be amorphous, the base layer **512** may be maintained to be transparent. That is, because the base layer **512** is formed to be in the amorphous state, light emitted from the organic light emission layer **720** can be irradiated to the exterior via the base layer **512** and the second substrate **200** without a large loss, so as to be implemented as an image.

[0068] The UV interception layer **522** is positioned on the base layer **512**.

[0069] The UV interception layer **522** formed on the base layer **512** may cover the base layer **512** covering the organic light emission layer **720**. The UV interception layer **522** formed on the base layer **512** may cover the entirety of the base layer **512**. The UV interception layer **522** includes a UV interception material. The UV interception material includes one or more of zinc oxide (ZnO), titanium oxide (TiO<sub>2</sub>), iron oxide (Fe<sub>2</sub>O<sub>3</sub>), and magnesium oxide (MgO). In other words,

the UV interception material may be one of zinc oxide (ZnO), titanium oxide (TiO<sub>2</sub>), iron oxide (Fe<sub>2</sub>O<sub>3</sub>), and magnesium oxide (MgO), and may be a mixture of the above material. The UV interception layer **522** including the UV interception material intercepts UV irradiated to the UV interception layer **522** from the exterior via the second substrate **200**. Because UV rays irradiated to the UV interception layer **522** via the second substrate **200** from the exterior are intercepted, UV irradiation from the exterior to the organic light emission layer **720** covered by the UV interception layer **522** may be restrained. That is, the life span of the organic light emission layer **720** covered by the capping layer **502** may be increased because of the UV interception function of the UV interception layer **522**.

[0070] Also, because the UV interception layer **522** is formed as the amorphous thin film by depositing the above-mentioned UV interception material by the atom or by the molecule, the capping layer **520** including the UV interception layer **522** can be maintained to be transparent. That is, because the capping layer **502** is formed to be in the amorphous state, light emitted from the organic light emission layer **720** may be irradiated to the exterior via the capping layer **502** and the second substrate **200** without a large loss of light emitted, so as to be implemented as an image.

[0071] The UV interception layer **522** is disposed spaced-apart from the second electrode **730** with the base layer **512** interposed between the UV interception layer **522** and the second electrode **730**. The UV interception layer **522** absorbs UV rays and prevents the organic light emission layer **720** to be irradiated by the UV rays, and in this case, the temperature of the UV interception layer **522** itself may increase due to the UV absorption. Even though the temperature of the UV interception layer **522** goes up as a result UV absorption, because the UV interception layer **522** is disposed spaced-apart from the second electrode **730**, an increase in the temperature of the second electrode **730** may be restrained according to thermal conduction over the increase in the temperature of the UV interception layer **522** itself. In other words, the thermal conductivity between the second electrode **730** and the UV interception layer **522** decreases because of the interposed base layer **512**. Namely, because the UV interception layer **522** absorbs UV in a state of being separated from the second electrode **730**, an increase in the temperature of the second electrode **730** resulting from the increase in the temperature of the UV interception layer **522** can be restrained, and thus, degradation of the second electrode **730** can be restrained.

[0072] As described above, because the OLED display device **102** constructed as the second exemplary embodiment includes the capping layer **520** having the UV interception layer **522** with a UV interception material, damage to the organic light emission layer **720** due to UV a and moisture and degradation of the second electrode **730** due to an increase in the temperature may be restrained, and thus, the lifespan of the OLED display device **102** may be increased.

[0073] While this disclosure has been described in connection with what is presently considered to be practical exemplary embodiments, it is to be understood that the invention is not limited to the disclosed embodiments, but, on the contrary, is intended to cover various modifications and equivalent arrangements included within the spirit and scope of the appended claims.

What is claimed is:

1. An organic light emitting diode (OLED) display device, comprising:

a first substrate;  
a first electrode positioned on the first substrate;  
an organic light emission layer positioned on the first electrode;  
a second electrode positioned on the organic light emission layer; and  
a capping layer positioned on the second electrode to cover the organic light emission layer, said capping layer comprising an ultraviolet (UV) interception material intercepting UV rays irradiated to the organic light emission layer from an exterior of the OLED display device.

2. The OLED display device of claim 1, wherein the UV interception material comprises one or more of zinc oxide, titanium oxide, iron oxide, and magnesium oxide.

3. The OLED display device of claim 2, wherein the capping layer is an amorphous organic film or an amorphous inorganic film.

4. The OLED display device of claim 3, wherein the capping layer comprises one or more of a-NPD, NPB, TPD, m-MTDATA, Alq3, LiF, and CuPc.

5. The OLED display device of claim 3, wherein the capping layer is an inorganic film comprising silicon (Si).

6. The OLED display device of claim 3, wherein the capping layer is deposited by the atom or by the molecule.

7. The OLED display device of claim 2, wherein the capping layer further comprises a UV interception layer comprising a UV interception material.

8. The OLED display device of claim 7, wherein the UV interception layer is separated from the second electrode.

9. An organic light emitting diode (OLED) display device, comprising:  
a first substrate;  
an organic light emitting element disposed on the first substrate, the organic light emitting element comprising

a first electrode, a second electrode and an organic light emission layer interposed between the first and second electrodes; and  
a capping layer covering the entirety of the organic light emitting element, and the capping layer intercepting ultraviolet (UV) rays irradiated to the organic light emission layer from an exterior of the OLED display device.

10. The OLED display device of claim 9, wherein the capping layer is a single layer, and the capping layer is an amorphous film comprising at least one of zinc oxide, titanium oxide, iron oxide, and magnesium oxide.

11. The OLED display device of claim 10, wherein the capping layer is an amorphous organic film comprising at least one of a-NPD, NPB, TPD, m-MTDATA, Alq3, LiF, and CuPc.

12. The OLED display device of claim 10, wherein the capping layer is an amorphous inorganic film comprising silicon (Si).

13. The OLED display device of claim 9, wherein the capping layer is a multiple layer comprising a base layer and a UV interception layer different from the base layer.

14. The OLED display device of claim 13, wherein the base layer is an amorphous organic film comprising at least one of a-NPD, NPB, TPD, MTDATA, Alq3, LiF, and CuPc.

15. The OLED display device of claim 13, wherein the base layer is an amorphous inorganic film comprising silicon (Si).

16. The OLED display device of claim 13, wherein the UV interception layer comprises at least one of zinc oxide, titanium oxide, iron oxide, and magnesium oxide.

17. The OLED display device of claim 13, wherein the UV interception layer is disposed spaced-apart from the second electrode.

\* \* \* \* \*

专利名称(译)	有机发光二极管显示装置		
公开(公告)号	<a href="#">US20110127498A1</a>	公开(公告)日	2011-06-02
申请号	US12/873003	申请日	2010-08-31
[标]申请(专利权)人(译)	三星显示有限公司		
申请(专利权)人(译)	三星移动显示器有限公司.		
当前申请(专利权)人(译)	三星DISPLAY CO. , LTD.		
[标]发明人	JUNG WOO SUK PARK SOON RYONG LEE DUK JIN UM SA BANG KIM JAE YONG		
发明人	JUNG, WOO-SUK PARK, SOON-RYONG LEE, DUK-JIN UM, SA-BANG KIM, JAE-YONG		
IPC分类号	H01L51/50		
CPC分类号	H01L51/5237 H01L51/524 H01L51/5253		
优先权	1020090117927 2009-12-01 KR		
其他公开文献	US9224978		
外部链接	<a href="#">Espacenet</a> <a href="#">USPTO</a>		

摘要(译)

有机发光二极管 ( OLED ) 显示装置包括第一基板;第一电极位于第一基板上;位于第一电极上的有机发光层;位于有机发光层上的第二电极;盖层位于第二电极上,以覆盖有机发光层,并包括紫外 ( UV ) 截取材料,拦截从外部照射到有机发光层的紫外线。

